

## 2" x 4" Applied Glass Stop

Scale: 1/4" = 1

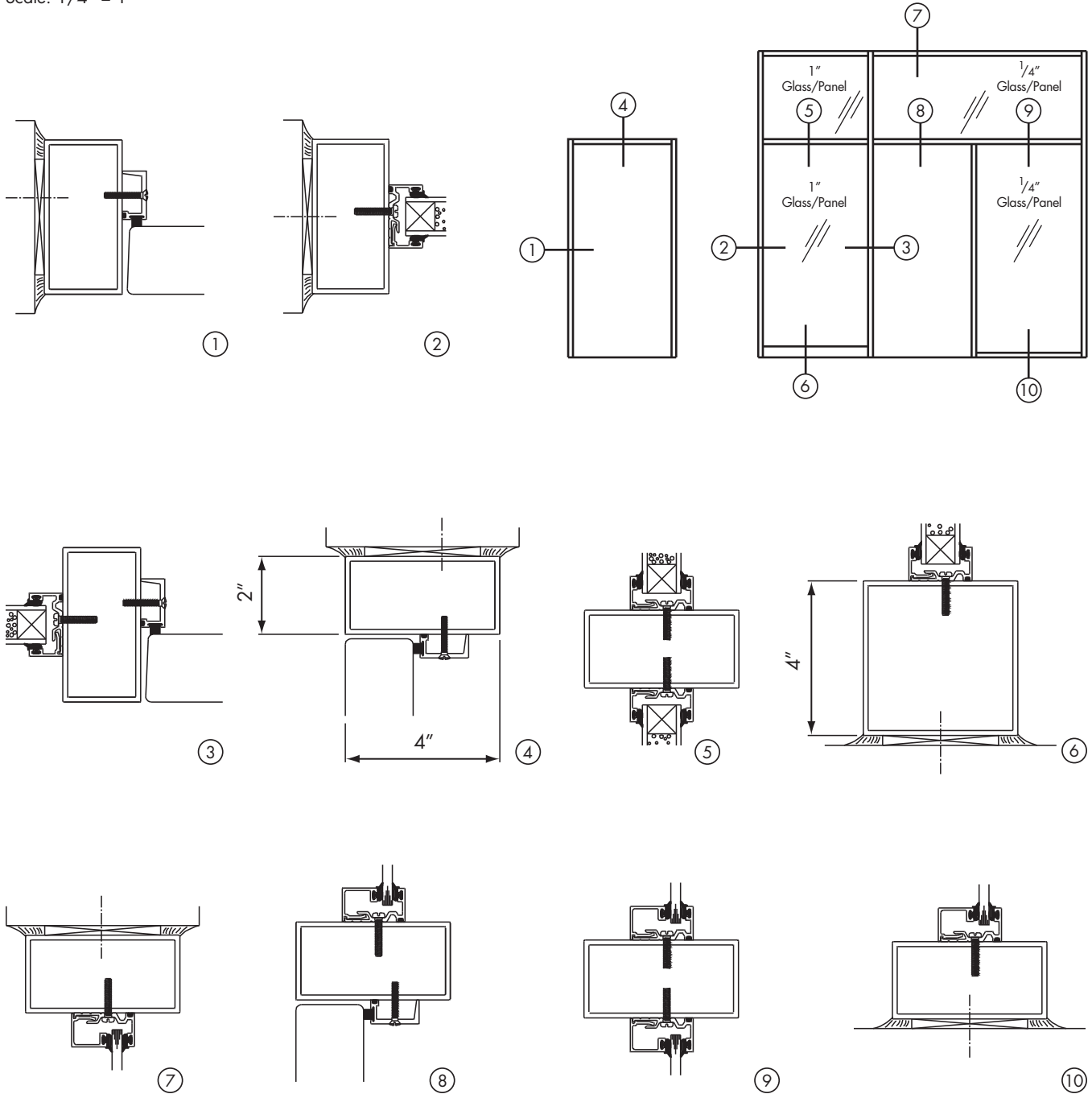

Product specifications and construction details subject to change without notification.

**Special-Lite, Inc.**

P.O. Box 6, Decatur, MI 49045

Ph: 800.821.6531 • Fx: 800.423.7610 • [www.special-lite.com](http://www.special-lite.com)

Item #7216  
3M 05/10 JBP