

FIELD INSTALLATION INSTRUCTIONS

SL-301 Adjustable Bottom Brush for Monumental Doors

Step #1

Remove door and hinge(s) from frame, and lay flat on suitable supports. If butt hinges are used, skip to step #2. If a continuous hinge is used, with hinge on door, mark center lines for a 1" hole through the hinge to provide access to the bottom brush adjusting screws, as shown in Figure 1. Remove hinge, drill and de-burr hole, and set hinge aside.

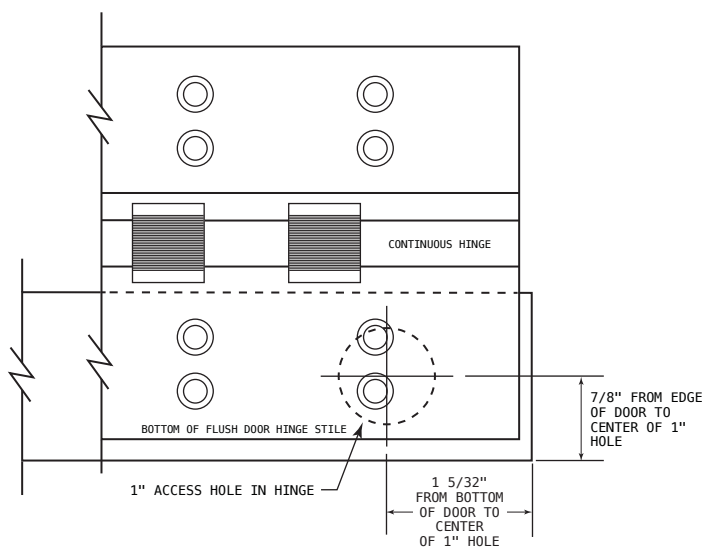

LAYOUT 1" ACCESS HOLE ON HINGE BEFORE REMOVING IT FROM DOOR. DRILL HOLE AFTER REMOVAL

FIGURE #1

Step #2

Remove any existing sweeps. Remove any surface-applied sweeps from door.

Step #3

Trim SL-301 unit to length. Remove the endplate from the brush unit. It is not used when installed in monumental doors. Measure the maximum width of the door (to the high bevel side) and record. Deduct 1/4" for each beveled stile, and 1/8" for each square stile, to determine the overall length for the unit. Cut unit to length and de-burr.

Step #4

Drill mounting and adjuster access holes.

Lock Stile: Referencing Figure 2, mark centerlines for holes in lock stile for mounting screws and drill two 1/4" holes and de-burr inside of stile. Countersink holes for #10 flat head screws provided.

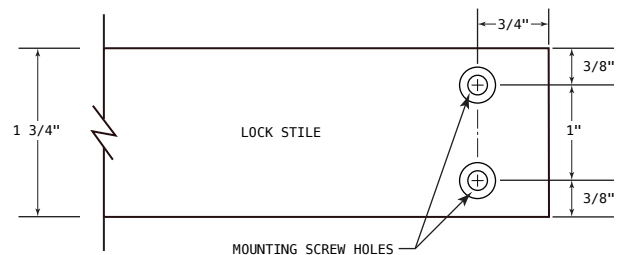

FIGURE #2

Hinge Stile: Referencing Figure 3, mark centerlines on hinge stile for holes for mounting screws and access holes for adjusting screws on unit. Drill two 1/4" holes for mounting screws and de-burr inside of stile. Countersink holes for #10 flat head screws provided. Layout centerlines and drill two adjustment screw access holes with 1/4" bit, and enlarge holes to 3/8". De-burr inside of stile.

A fixture is available from Special-Lite to speed up drilling of these holes if multiple doors are to be retrofit (order drill fixture 301-M54).

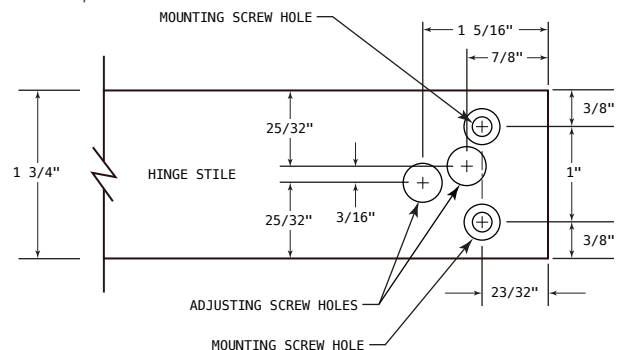

FIGURE #3

SL-301 Adjustable Bottom Brush for Monumental Doors

Step #5

Fit unit into bottom rail. If door is equipped with a flush bolt, remove bolt and guide bracket now. The adjusting screws on the unit protrude into the access holes in the hinge stile, so unit should be inserted into bottom rail cavity adjusting end first. Test fit unit and adjust length if necessary.

Step #6

Flush Bolt Prep. Skip this step if door is not equipped with flush bolts. If door has flush bolts, use the old guide bracket as a template for prep shape and backset. Hand machine a "D" shaped hole through the brush carrier extrusion of the unit, and drill a 5/8" clearance hole through the top housing extrusion. Use the bolt to check final size of the prep and clearance hole alignment.

Step #7

Secure unit in door. Install unit into cavity in bottom rail. Use four #10 flathead screws provided through stiles to secure the unit to the door. Locate center support screw access hole, which is slightly off center in middle of unit and drill through bottom web of rail with a #21 or 11/64" drill. Install the 10-16 x 1 phillips pan head screw provided into the bottom web of the rail at center support location.

Step #8

Install dual brushes. With unit in door, turn adjusting screws counterclockwise to extend the brush carrier out for installation of dual brushes. Cut two brushes to length of slots in bottom of unit. Slide the brushes into slots and secure by crimping the reglet at both ends of brush with pliers or side cutters. If door is equipped with flush bolts, reinstall to original depth. Return brushes back to the fully retracted position before reinstalling door.

Step #9

Reinstall door and adjust brush height. After reinstalling door, close door and inspect brush clearance above threshold to estimate required brush extension. Each full turn of the adjusting screws equals 3/64" movement. Open door to access the adjusting screws and turn counterclockwise to lower the brushes. Close the door to check clearance and repeat the process until the brushes show slight flexing but little resistance to closing. Also check for light coming in under the brush, and add slightly more pressure if needed.

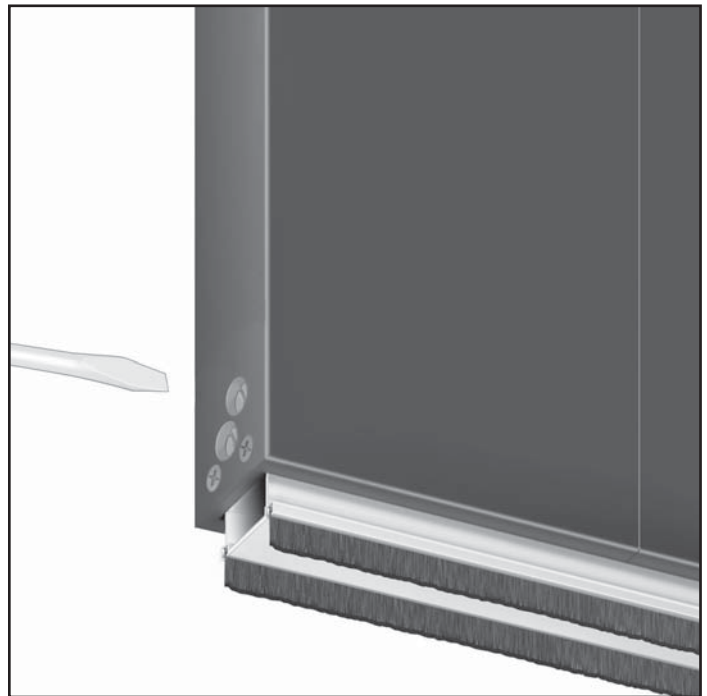

Adjustment of bottom brush on hinge side of door