

High-Performance Commercial Entrance Systems



Monumental Doors



Aluminum Flush Doors



FRP Flush Doors



AMP Flush Doors

Longer Service Life for Lowest Life Cycle Cost

Special-Lite produces flush and monumental doors, framing, panels, hardware, and vision lites for the most demanding commercial applications. Since 1971, we've been solving entrance problems with high-performance products engineered and manufactured to provide the longest possible service life with minimal maintenance. The key is our unique design philosophy and manufacturing approach. We make our doors lightweight and flexible to deliver strength and endurance that other doors can't match. As a result, our entrances deliver the lowest life cycle cost. And, we stand behind our products with a 10-year no-nonsense warranty.



Better Quality of Life

Special-Lite® Entrance Products offer many advantages for green buildings. They are the first entrance products to be GREENGUARD Indoor Air Quality Certified®—including the stringent new GREENGUARD Standard for Children and Schools™. GREENGUARD Certification is your independent assurance that Special-Lite products meet the country's toughest indoor air quality criteria.

Our products leave our factory pre-finished so they don't need to be painted at installation or regularly repainted, eliminating the associated health risks. Our lightweight door design extends the service life of the entire entrance, including hardware. And, thanks to our durable stain-resistant finishes, even most tough stains like graffiti can be removed using environmentally responsible cleaners.

For more reasons why our entrances are the best choice for sustainable construction, visit our web site at www.special-lite.com/sustain.

Bring Your Vision to Life

From preserving a historic façade to making a bold architectural statement, Special-Lite can supply a complete entrance system that's a perfect fit, and deliver it in one, on-time shipment. Unique sizes, configurations, and custom lites are no problem. Our technical staff can help with design ideas, finish samples, submittal drawings, or computer-generated concept renderings. We offer a wide variety of anodized finishes, paint colors, and surface textures, and we can match any custom color.

The GREENGUARD INDOOR AIR QUALITY CERTIFIED Mark is a registered certification mark used under license through the GREENGUARD Environmental Institute.

Flush Doors

Heavy-duty engineering makes for heavy-duty doors

Special-Lite® Flush Doors are heavy-duty doors, engineered to provide maximum performance and strength with minimum weight. This makes them easier to open for ADA compliance, and reduces wear and tear on the entire entrance system.

The high performance of our flush doors is made possible by advanced design features such as mitered corners, full-width tie rod joinery, locked-in-place face sheets, and a poured-in-place urethane foam core that bonds the door components into a single, integral unit. This gives our flush doors just the right balance of flexibility, rigidity, and impact resistance.

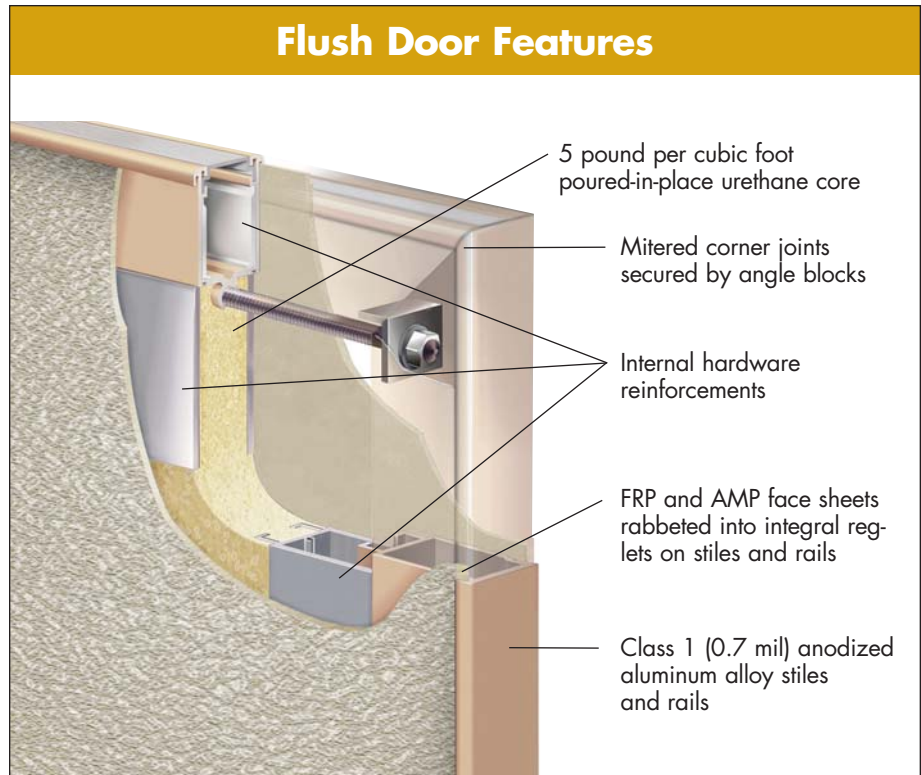

Aluminum Flush Doors

Lightweight beauty, but not light-duty

When aesthetic considerations are as important as ease of maintenance and long life, Special-Lite® Aluminum Flush Doors (SL-16) are perfect. They provide an attractive, easy-care option where reduced glass area is desired, but only moderate abuse is expected. They offer excellent design flexibility and provide an elegant, contemporary look in commercial and educational applications with moderate to heavy traffic. Challenging conditions such as high humidity or corrosive chemicals are no problem, which makes our aluminum doors a good choice for water and wastewater treatment plants and industrial facilities. In addition, a model with stainless steel face sheets (SL-16SS) is available for sanitary environments such as hospitals, laboratories, and kitchens.

The SL-16 is available in all of our anodized finishes or painted color choices, or your own custom color. Three different surface textures are available: smooth, embossed and fluted. The SL-16 features durable .062" face sheets. Custom door sizes are available up to 48" x 120".

FRP Flush Doors

Tough doors for the real world

Special-Lite pioneered the use of FRP (Fiberglass Reinforced Polyester) on flush doors in 1981 to meet the extreme demands of the school market. Special-Lite® FRP Doors (SL-17) offer trouble-free performance and long-lasting beauty in the most challenging interior and exterior applications. Remarkably durable, they can withstand heavy traffic, abuse, or adverse environmental conditions and stay new looking for years. The door of choice for schools, they are also ideal for industrial or municipal facilities where corrosion resistance and ease of cleaning are required. They're so tough that our standard SL-17 is Hurricane-Rated and has achieved Florida Product Approval, including the High Velocity Hurricane Zone.

Our SL-17 model features our exclusive Speclite 3® FRP face sheet. It's amazingly dent, scratch, scuff, stain and corrosion resistant, is .120" thick, and is available in a



variety of through-and-through colors. The SL-17 is available in custom door sizes up to 80" x 216". A smaller version (SL-175) is available for correctional or institutional toilet and shower doors.



AMP Flush Doors

The warmth of wood without the work

Special-Lite® AMP (Acrylic-Modified Polyester) Flush Doors in Colonial (SL-18) and

Wood Grain (SL-19) models combine traditional styling with the advantages of modern materials and engineering to deliver high performance and long life. Our AMP doors feature a face sheet that offers the attractive appearance of wood, but unlike wood doors can't warp, split, peel, or rot, and don't require regular refinishing. They're durable enough for even high traffic entrances in school, religious, retail, and civic facilities that call for the classic appearance of a wood door.

Special-Lite AMP Flush Doors are available in natural wood stain or painted finishes. AMP face sheets are .120" thick. The SL-18 is available in custom sizes from 30" x 80" to 48" x 96", and the SL-19 is offered in custom sizes up to 48" x 96".

Fire-Rated Doors

To complement our line of FRP and AMP Flush Doors, we manufacture FRP-Clad and AMP-Clad Fire-Rated Doors available with 30, 45, 60 and 90-minute ratings, as singles or pairs up to 4' x 8' per leaf. They're Warnock Hersey



Fire-Rated Door Models

SL-21	FRP-Clad Fire-Rated Door
SL-22	AMP-Clad Fire-Rated Door

listed for fire-rated applications in the United States, and are available in any of our standard or custom painted color options. Edge capping and vision lite kits are natural finish stainless steel.

Monumental Doors

A full-vision door for heavy traffic applications

Special-Lite® Monumental Doors allow you to create the open and inviting full-vision entrance you want, with the functionality, security, and long life you need. A wide variety of mid-rail and mid-panel possibilities and flush pull options allow you to create extremely functional and durable entrances ideal for educational, institutional, commercial, or religious facility openings subjected to high traffic. The attractive and durable finishes on these doors never need painting, cannot rust, and will keep their like-new appearance for years with only routine cleaning. Whether you choose the SL-14 Medium Stile (3 5/8") or SL-15 Wide Stile (4 1/2"), Special-Lite offers the best value in a durable full-vision door.

Monumental Door Features

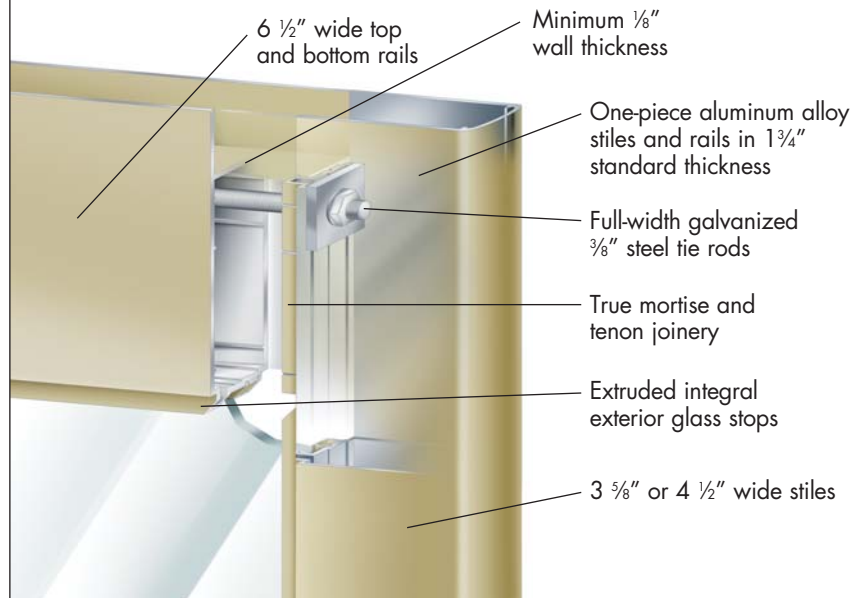

Hardware & Lites

Specifically designed to complement our door and framing products, we manufacture hardware and vision lite products that can enhance the functionality, security, and safety of your entrance. We can supply doors with hardware already installed, either produced by Special-Lite or by others, or we can just prep for field installation of hardware. When factory-installed, the installation is warranted against coming loose from the door for the entire 10-year warranty period. Hardware, accessories, and lite kits are available in a wide variety of available anodized finishes and painted colors.

Special-Lite, Inc.

P.O. Box 6,
Decatur, Michigan 49045
Fx: 800.423.7610



Framing & Panels

With a wide variety of Special-Lite® Framing products from which to choose, you can specify the frame that's perfect for your application. We offer heavy-duty tube framing

in many different sizes, in both flush glazed and applied stop configurations. For adjoining glass areas we also offer a storefront framing product, including thermally-improved models. Our insert frames provide a means of returning openings to a plumb and square condition when renovating a building or just replacing doors. If existing framing is still solid but too unsightly to leave exposed, our capping system can be used with insert frames to cover the old frame in place. Our framing products are factory assembled with minimal knockdown for shipping. Panels can be manufactured in any of our flush door face sheet materials.